

Installation Instructions

for DesignRail® 24VDC LED Lighting

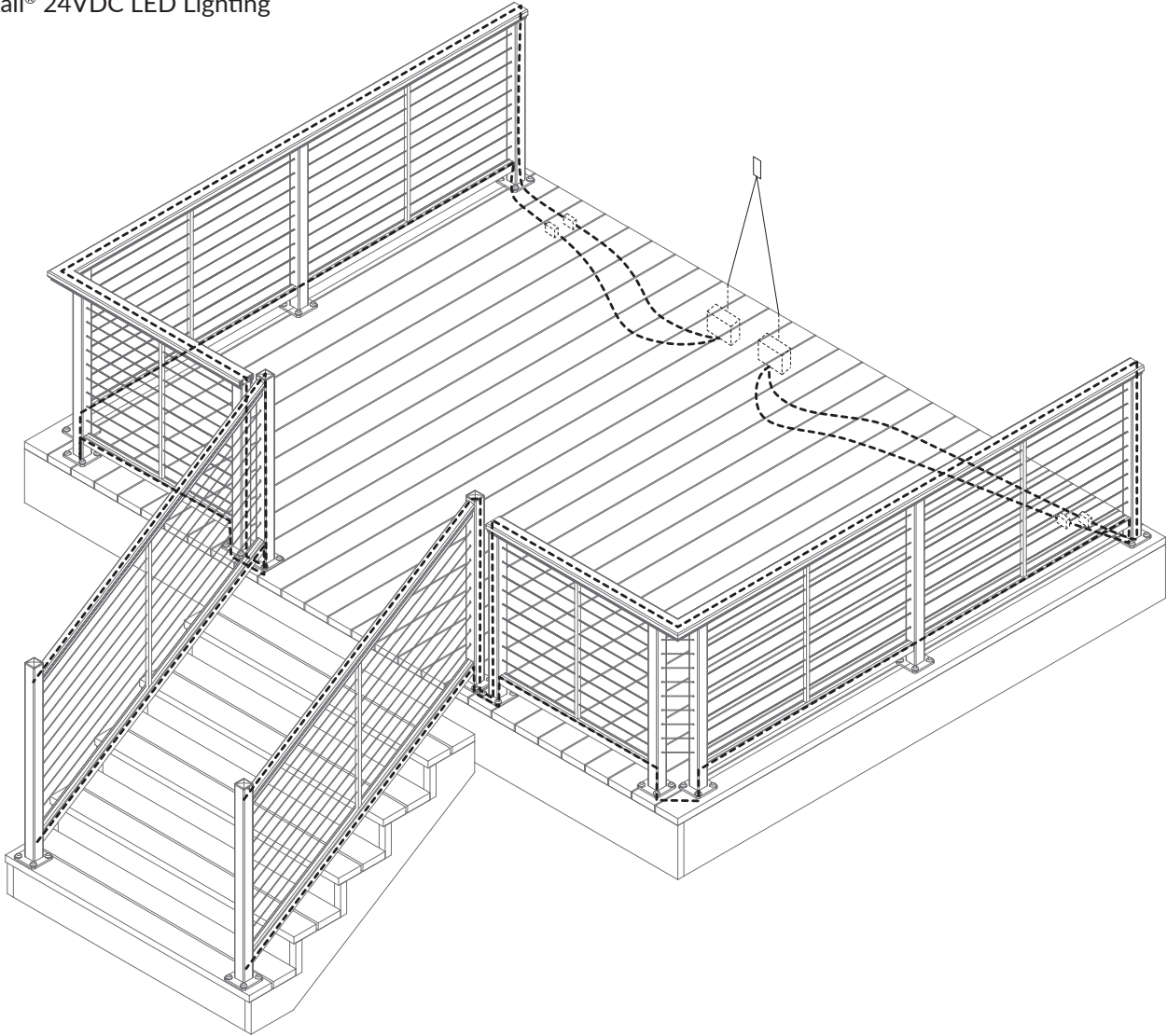

Drivers are available in a variety of wattages. In general a driver should not exceed more than 80% of its rated wattage. (Example: 60W Driver = $60 \times 0.8 = 48\text{W Max}$).

Strip Lights require 1.44 watts per foot. After determining the necessary length of strip lighting, calculate the wattage and ensure the driver being used has adequate capacity. (Example: $10' = 10 \times 1.44 = 14.4\text{W}$)

The maximum length of strip lighting that can be connected in one run is 25 feet. If one section of lighting is longer than 25 feet, it must be broken into multiple smaller sections and run on separate circuits.

Building codes vary by location and jurisdiction. Consult all applicable codes before installing DesignRail® LED Lighting. DesignRail® LED Lighting may not be suitable for every application and it is the sole responsibility of the installer to ensure that DesignRail® LED Lighting is used for its intended purpose.

WARNING: ELECTRIC SHOCK IS ALWAYS POSSIBLE WHEN WORKING WITH ELECTRICITY. THIS CAN CAUSE SERIOUS PERSONAL INJURIES OR DEATH. ELECTRICAL SHORTS CAN ALSO CAUSE FIRES AND PROPERTY DAMAGE. ALWAYS MAKE SURE THE ELECTRICAL OUTLET YOU ARE PLUGGING INTO IS GROUNDED.

Power Kits

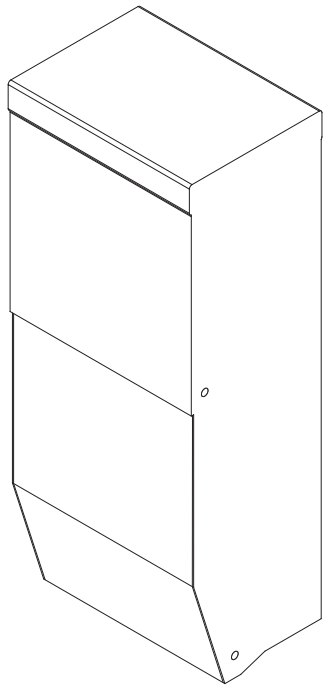

24V MAGNETIC DIMMABLE DRIVER
(SKU # VARIES BY WATTAGE)

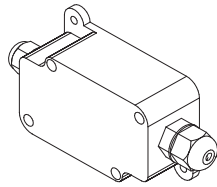

COMMERCIAL GRADE
WET LOCATION
MINI JUNCTION BOX
(SKU #7680)



ISOLATION
BUSHING
(SKU #1114)



WIRE NUTS
(PAIR)
(SKU #7670)

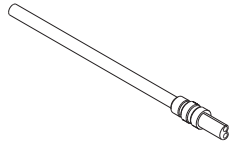

SOLDER CONNECTOR (UL)
(MALE ONLY)
(SKU #7673)

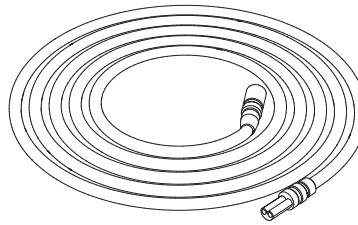

11' EXTENSION CABLE (UL)
(SKU #7650)

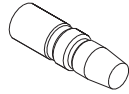

TERMINATOR CAP
(FEMALE ONLY)
(SKU #7671)

KIT CONTENTS

SKU #7683 - 96w Power Kit

- 1x 96w Dimmable Driver
- 2x Mini Junction Box
- 2x 11' Extension Cable
- 2x Wire Nuts (Pair)
- 2x Solder Connector
- 2x Isolation Bushing (1114)
- 2x Terminator Cap

SKU #7682 - 60w Power Kit

- 1x 60w Dimmable Driver
- 2x Mini Junction Box
- 2x 11' Extension Cable
- 2x Wire Nuts (Pair)
- 2x Solder Connector
- 2x Isolation Bushing (1114)
- 2x Terminator Cap

SKU #7681 - 40w Power Kit

- 1x 40w Dimmable Driver
- 1x Mini Junction Box
- 1x 11' Extension Cable
- 1x Wire Nuts (Pair)
- 1x Solder Connector
- 1x Isolation Bushing (1114)
- 1x Terminator Cap

LED Light Strips and Components

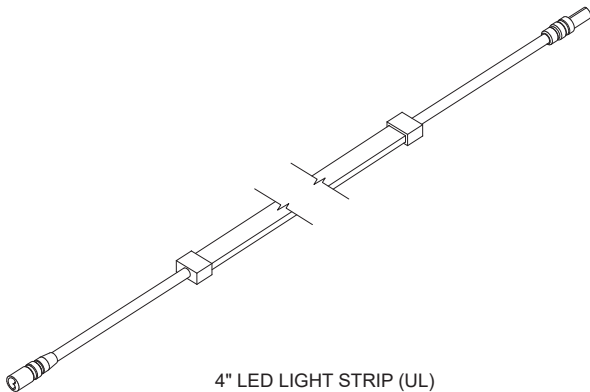

4" LED LIGHT STRIP (UL)
(SKU # LTS : W-4)

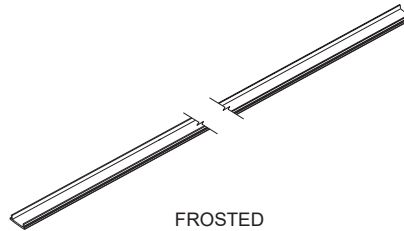

FROSTED
DIFFUSER LENS
(36" - SKU #7663)

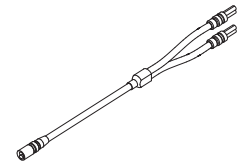

2 WAY WATERPROOF
SPLITTER (UL)
(SKU #7668)

12" LED LIGHT STRIP (UL)
(SKU # LTS : W-12)

20" LED LIGHT STRIP (UL)
(SKU # LTS : W-20)

32" LED LIGHT STRIP (UL)
(SKU # LTS : W-32)

56" LED LIGHT STRIP (UL)
(SKU # LTS : W-56)

68" LED LIGHT STRIP (UL)
(SKU # LTS : W-68)

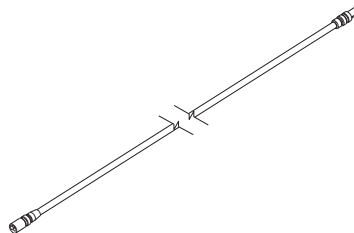

12" EXTENSION CABLE (UL)
(SKU #7719)

40" EXTENSION CABLE (UL)
(SKU #7669)



ISOLATION BUSHING FOR
BOTTOM RAIL/100 SERIES
LIGHTING
(SKU #1114)

Power Kits - Installation

Step 1 - Connect Source Power to Driver

IMPORTANT SAFETY NOTE: TO REDUCE RISK OF ELECTRICAL SHOCK, TURN OFF AC CIRCUIT BREAKER PRIOR TO COMMENCING ANY ELECTRICAL WORK AND CONNECTING DRIVER(S) TO AC POWER SOURCE. VERIFY THAT LIVE POWER IS NOT PRESENT AT JUNCTION BOX WHEN MAKING CONNECTIONS.

Determine location of driver.

Note: It is best to locate the drivers as close as possible to the lighting to reduce the possibility of voltage drop occurring. If possible, the driver enclosure should be within 5 feet of the post that will accept the 11' extension cable, acting as the lead wire to the first strip light. If necessary, up to 30 feet of 14 AWG wire can be used between the driver and the 11' extension cable.

Route exterior rated wiring from compatible dimmer switch/AC power source to location of driver.

Connect drivers to dimmer switch/AC power source using wire nuts.

Connect 11' extension cable(s) and route outside of driver to post.

If necessary, run up to 30 feet of 14 AWG wire to a wet-location mini junction box and transition to solder connector.

TOP RAIL LIGHTING - WIRING DIAGRAM

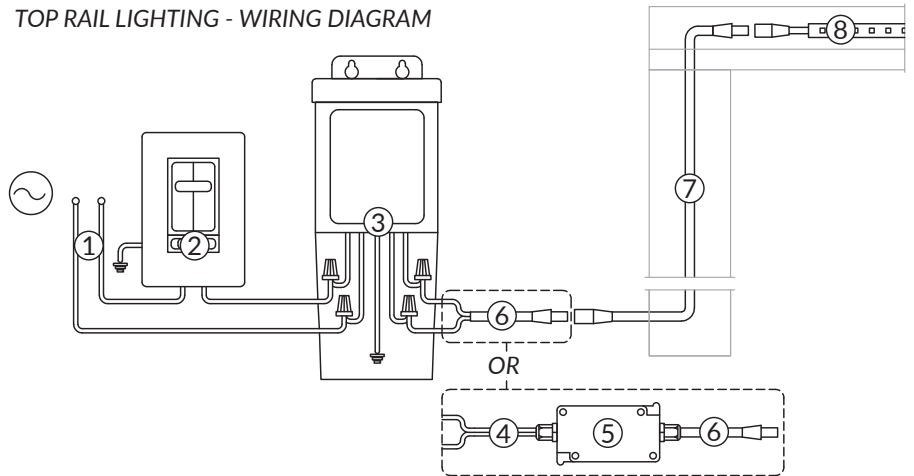

BOTTOM RAIL LIGHTING - WIRING DIAGRAM

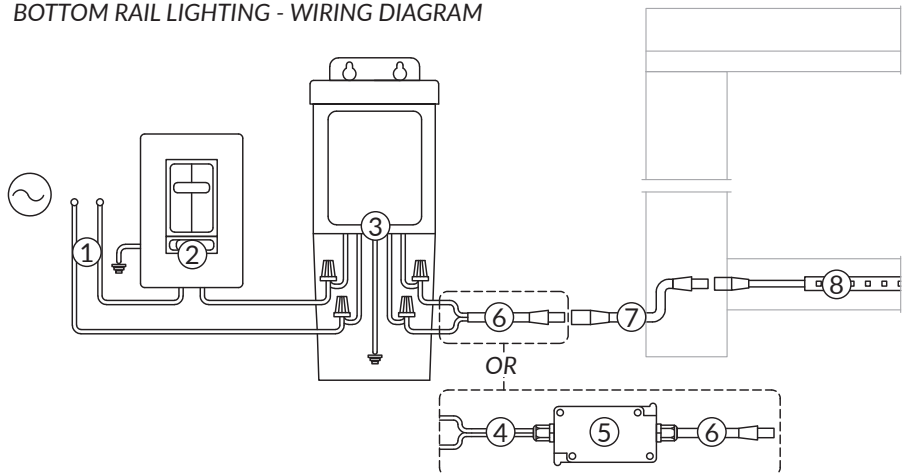

TOP & BOTTOM RAIL LIGHTING - WIRING DIAGRAM

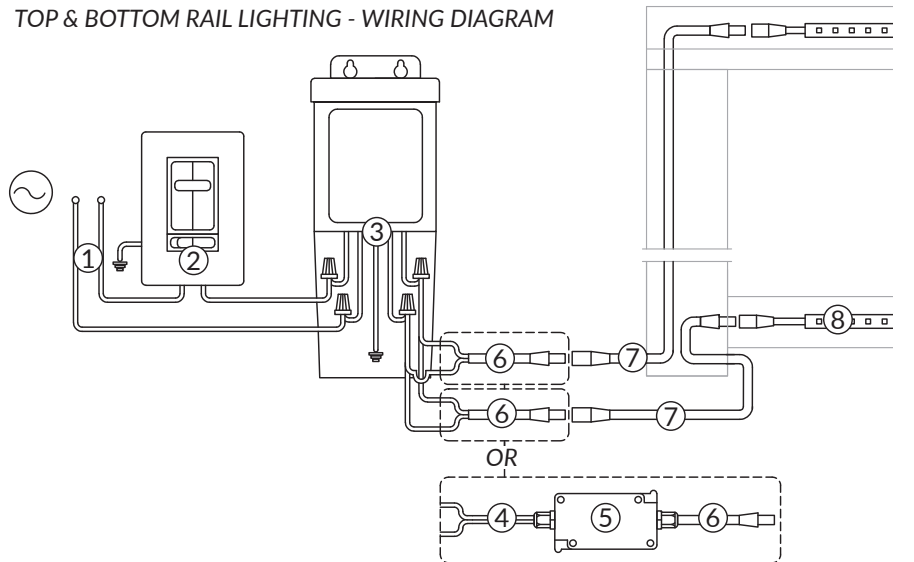

Note: If using both top and bottom rail lighting, run each on their own circuit.

LIGHTING COMPONENTS

1. Power (by customer)
2. Light Switch (by customer) ¹
3. 24v Dimmable Driver ²
4. 14 Gauge Wire (by customer)
5. Mini Junction Box
6. Solder Connector
7. 11' Extension Cable
8. LED Light Strip

1. Mount vertically only. See Switch Compatibility Spec Sheet at www.feeneyinc.com
 2. See Driver Spec Sheet at www.feeneyinc.com

STEP 2 - DRILL POSTS AND ROUTE LEAD WIRE

Note: Running the lead wire through the post is easier when done prior to mounting post.

Determine location that lead wire will enter post.

Note: Depending on the post mounting method, and enclosure location relative to the post, the lead wire entrance point may vary. (See Figure 1.2 for typical recommendations)

Drill 1/2" diameter hole in post at desired lead wire entrance location and insert supplied grommet, part #1114. (See Figure 1.1)

For Series 150: drill a 1/2" diameter hole vertically centered between the top RCB holes and insert supplied grommet (See Figure 1.3). This will allow the light strip wiring to pass through the RCB hollow. Repeat this step for each post which will have light strips running through it.

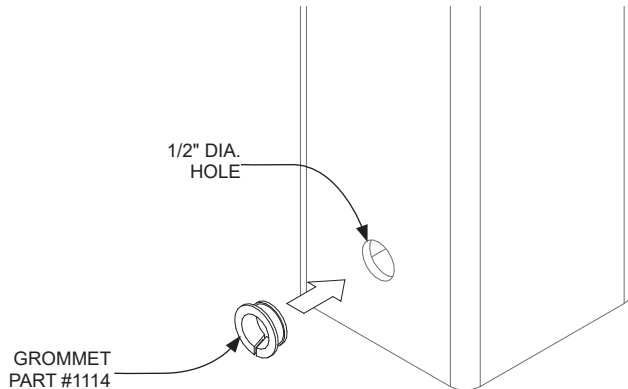

Figure 1.1

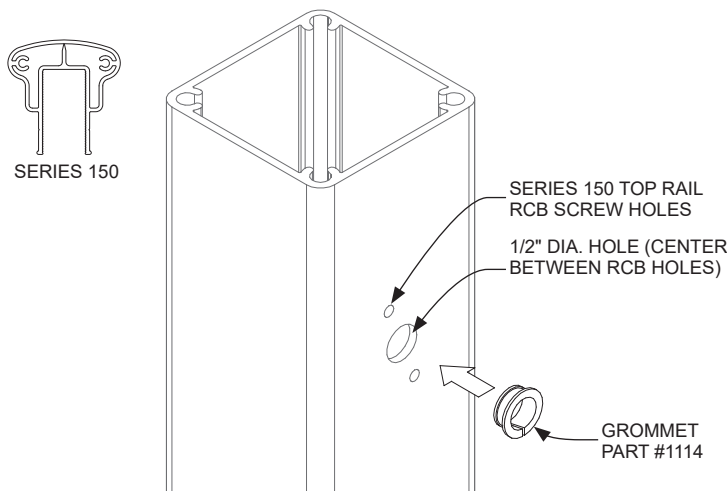

Figure 1.3

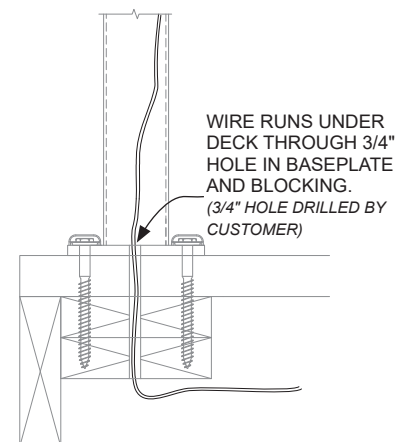
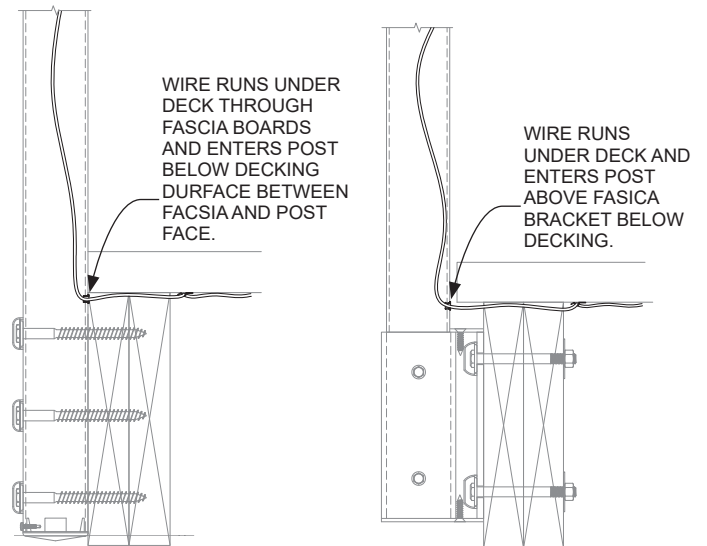
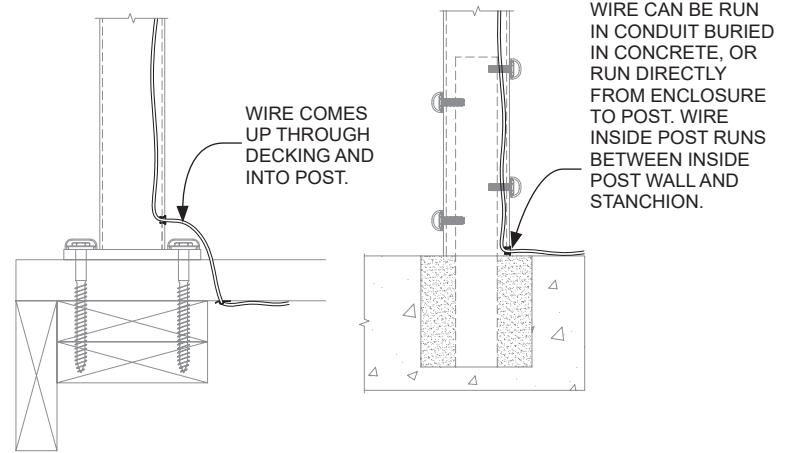

Figure 1.2

STEP 2 CONT.

If installing bottom rail lighting: drill a 1/2" dia. hole, at 7/16" below and centered between the bottom rail RCB holes and insert grommet. (See Figure 1.4) Repeat this step for each post which will have light strips running through it.

Insert lead wire into grommet hole, then fish through post as necessary:

- If installing top rail lighting only: Attach additional 11' extension cable to be run to the top of the post. Use an additional 40" extension cable, if necessary. (See Figure 1.5)
- If installing bottom rail lighting only: Fish lead wire through hole under RCB. (See Figure 1.6)

Pull top rail lead wire out through top of post (See Figure 1.8).

Note: For Series 150: Lead wire will pass through grommeted hole at top of post. Use masking tape to temporarily secure lead wire(s) to outside of post to prevent retracting back into post.

Post can now be mounted per DesignRail installation instructions.

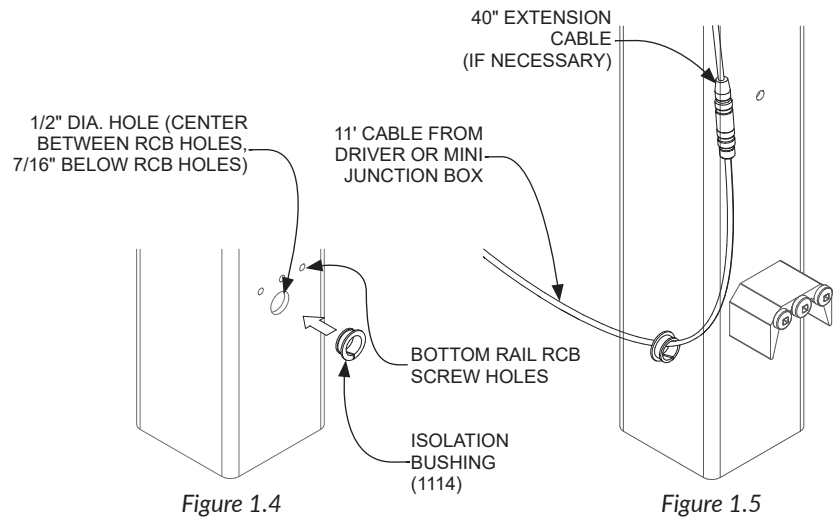

Figure 1.4

Figure 1.5

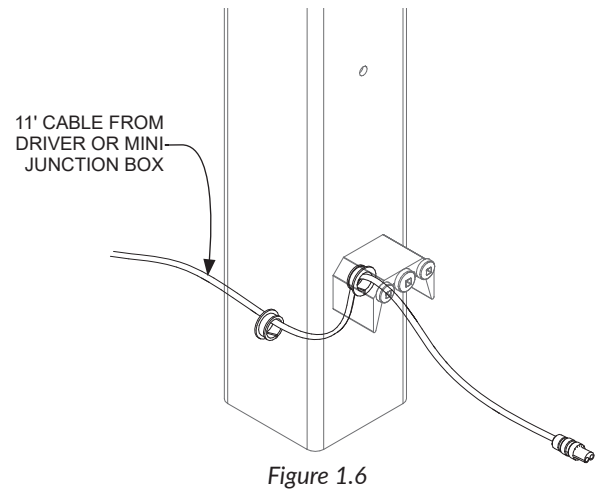

Figure 1.6

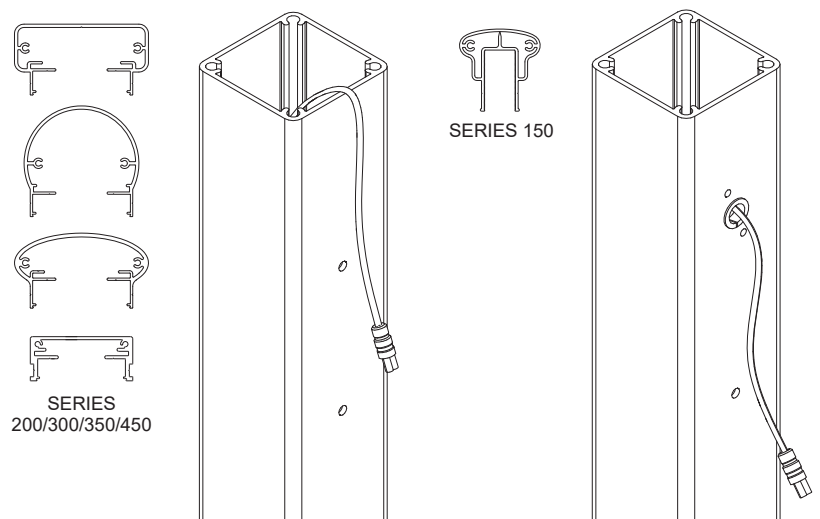

Figure 1.8

Light Kits - Top Rail Installation

Step 1 - Prepare Railing Frame

For Series 200/300/350/450: attach 3/4" wide piece of standard infill to top of intermediate pickets using #10 x 3/4" screw (See Figure 2.1).

For Series 150: intermediate picket can be directly attached to flange of channel.

Follow standard DesignRail installation instructions for attaching bottom rail, or picket base plate, and install picket sub-assembly panels. (Standard DesignRail with Horizontal Cable Steps 11-13)

For Series 200/300/350/450: measure the opening between the picket and post face on each side of the picket (See Figure 2.2). These dimensions should be equal.

For Series 200/300/350/450: cut top rail insert for lighting, to fit on each side of the picket.

Install top rail insert on each side of picket. Avoid pinching lead wire by starting insert at a slight angle and rotating up and into top rail (See Figure 2.3).

Secure intermediate picket to top rail.

For Series 200/300/350/450: Use (2x) #8 x 1" self-tapping screws (See Figure 2.4).

For Series 150: intermediate picket should already be attached to flanges on top rail.

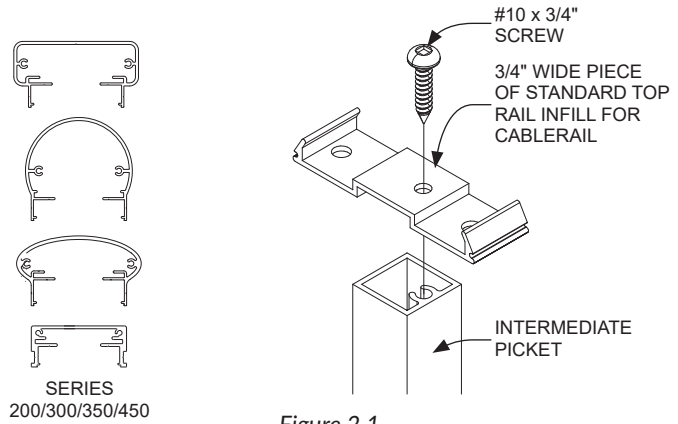

Figure 2.1

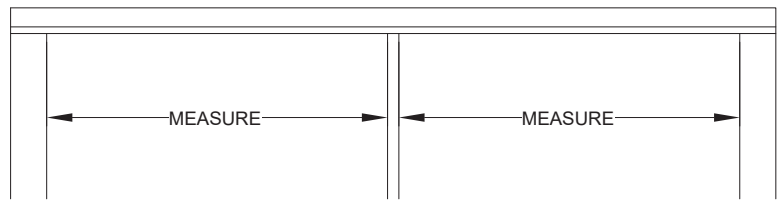

Figure 2.2

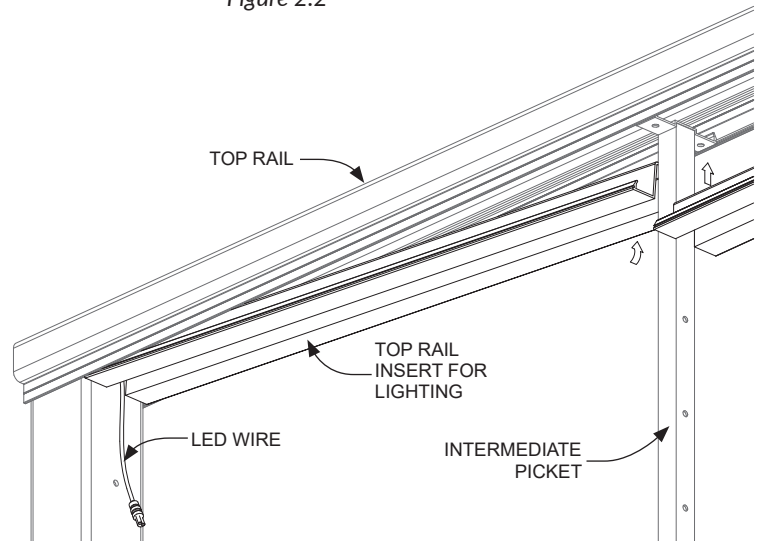
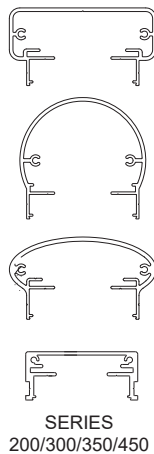

Figure 2.3

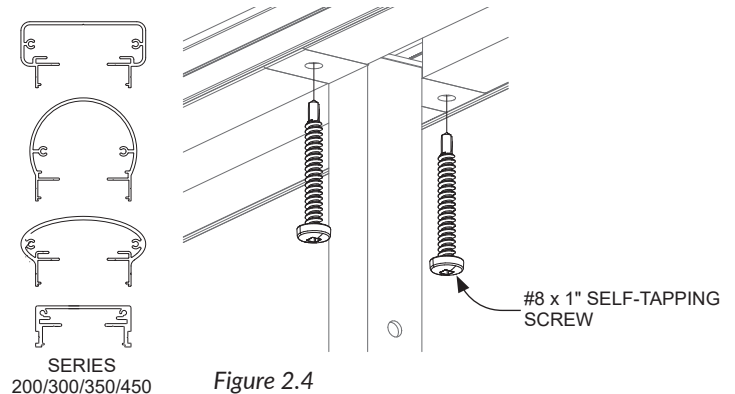

Figure 2.4

Step 2 - Install Strip Lights

Attach female connector of light strip to male connector of top rail lead wire (See Figure 2.5).

Remove adhesive strip cover and discard. Insert light strip into insert channel, while feeding lead wire back into post and routing opposite end connector up and over intermediate picket. Follow included mounting instructions for adhesive strip to ensure proper bond (See Figure 2.6).

Stuff excess wiring back into post, or in gap above intermediate picket. Avoid allowing wiring to hang below light strip, as this can create 'cold spots' by blocking the light from emitting through the diffuser lens.

Continue 'daisy-chaining' light strips together by connecting female connector to male connectors, for up to 25 feet.

Attach end cap to male connector end of final light strip (See Figure 2.7).

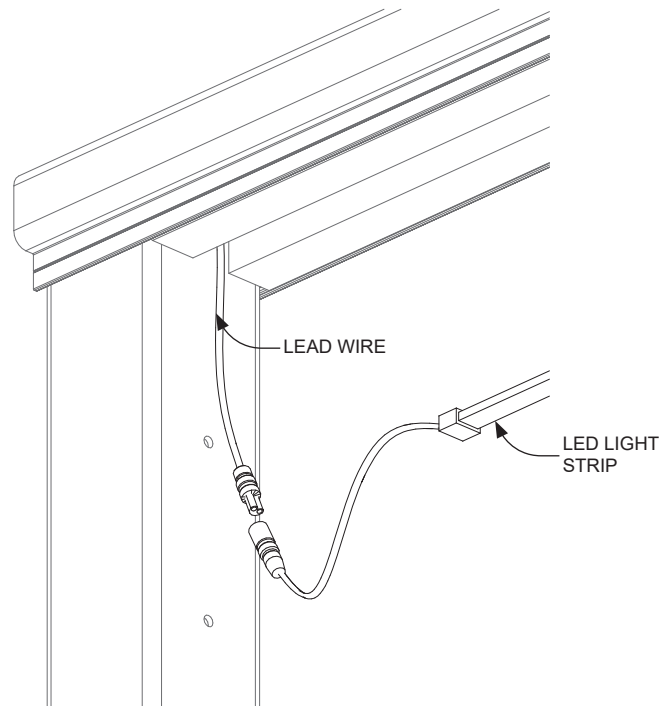

Figure 2.5

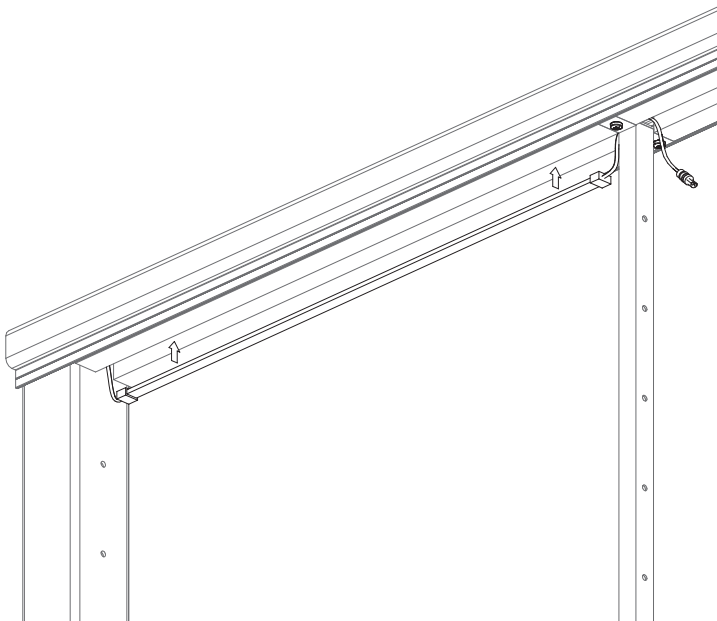

Figure 2.6

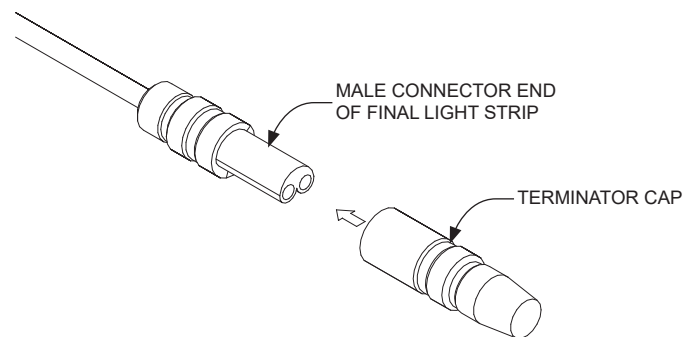

Figure 2.7

Step 3 - Install Diffuser Lens

Measure the opening between the picket and post face on each side of the picket (See Figure 2.8). These dimensions should be equal.

Cut diffuser lens to length to fit on each side of the picket, using a sharp utility knife, or heavy duty utility scissors/shears.

For Series 150: trim 1-1/4" of the 'tension flanges' at the end of the diffuser lens that will be under the top rail RCB. Trimming is best done with a small backsaw or sharp utility knife. This will keep the diffuser lens from interfering with the bottom of the RCB. (See Figure 2.9).

Insert diffuser lens into top rail insert, or top rail flanges, as shown. (See Figure 2.10)

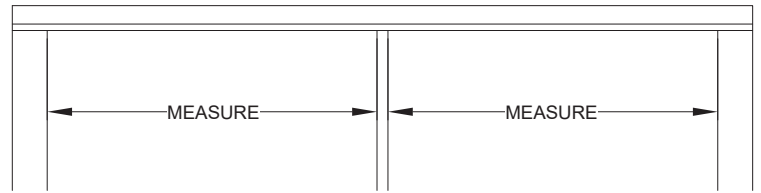

Figure 2.8

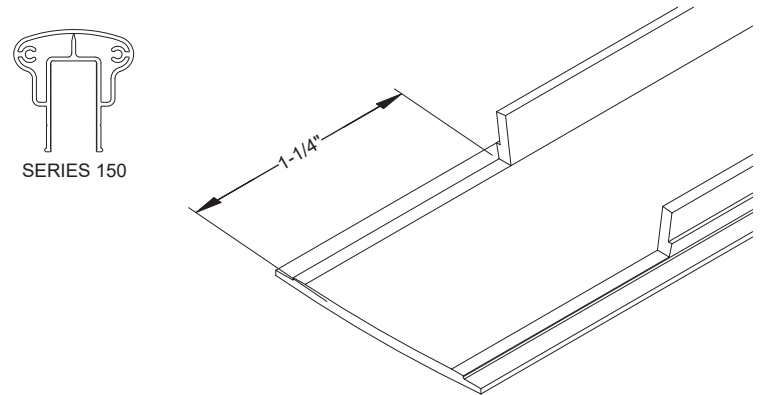
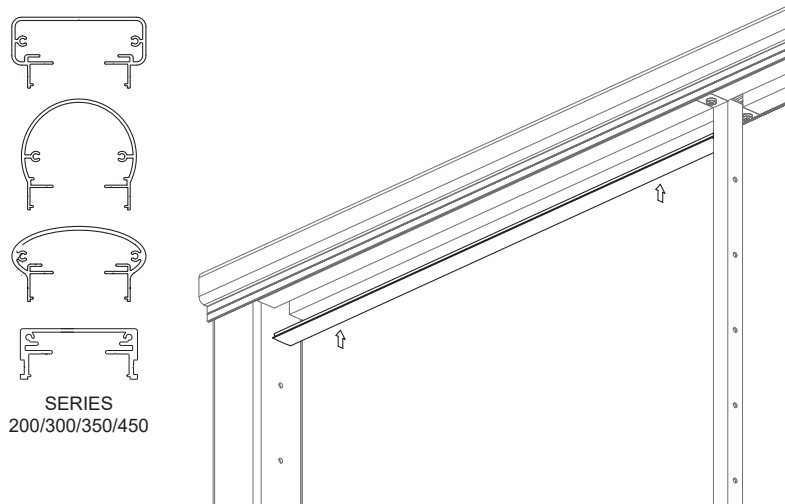
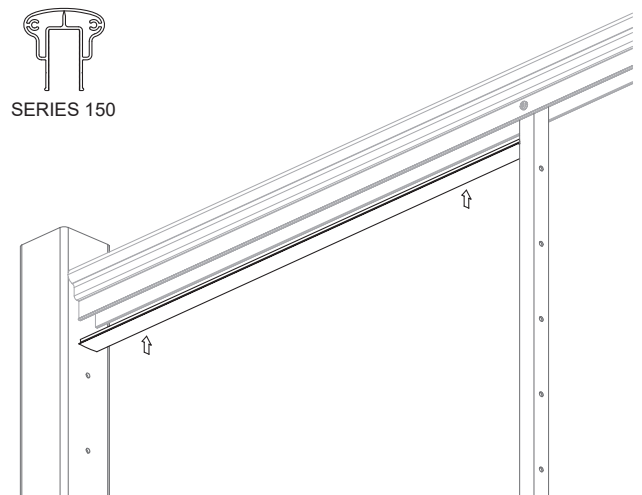

Figure 2.9



SERIES
200/300/350/450



SERIES 150

Figure 2.10

Light Kits - Bottom Rail Installation

Step 1 - Prepare Railing Frame

Measure opening between the post faces beneath the bottom rail (See Figure 3.1).

Cut channeled bottom rail insert to fit between posts.

Trim channel portion of insert at both ends to clear RCBs. This can be done by cutting the 'top' of the channel to a point just above the flanges, then 'snipping' the sides to remove (See Figure 3.2).

Install bottom rail insert between posts (See Figure 3.3).

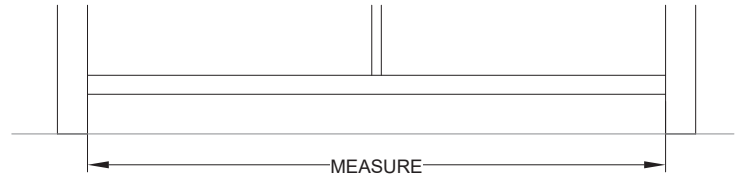

Figure 3.1

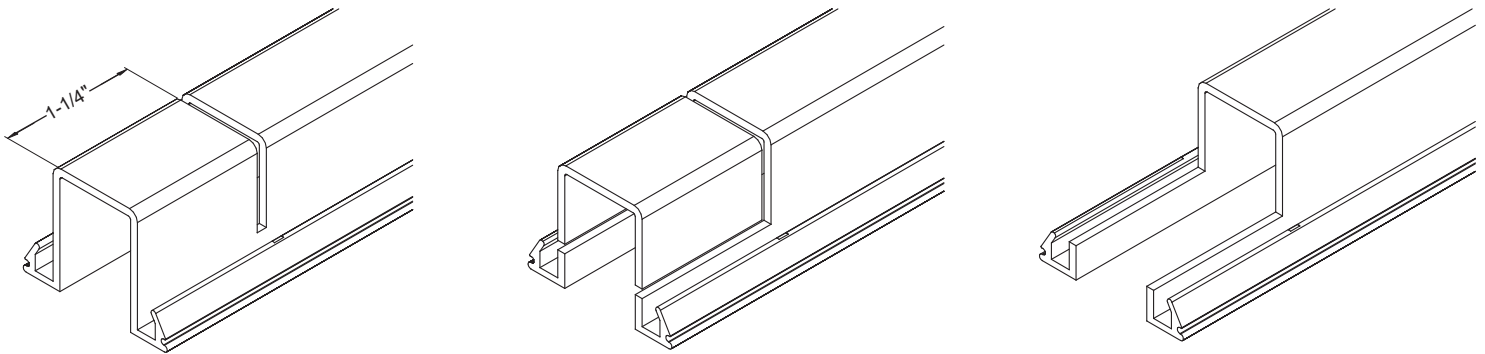

Figure 3.2

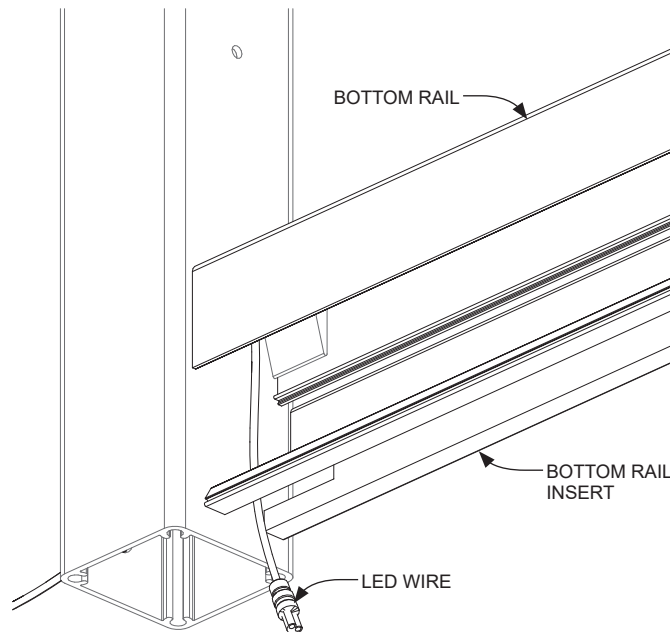

Figure 3.3

Step 2 - Install Strip Lights

Attach female connector of light strip to male connector of top rail lead wire (See Figure 3.4). If necessary attach additional light strips to male connector to fill entire length of bottom rail channel

Remove adhesive strip cover and discard. Insert light strip into bottom rail infill channel, while feeding lead wire back into post. Follow included mounting instructions for adhesive strip to ensure proper bond (See Figure 3.5).

Stuff excess wiring back into post. Avoid allowing wiring to hang below light strip, as this can create 'cold spots' by blocking the light from emitting through the diffuser lens.

Continue 'daisy-chaining' light strips together by connecting female connector to male connectors, for up to 25 feet.

Attach end cap to male connector end of final light strip (See Figure 3.6)

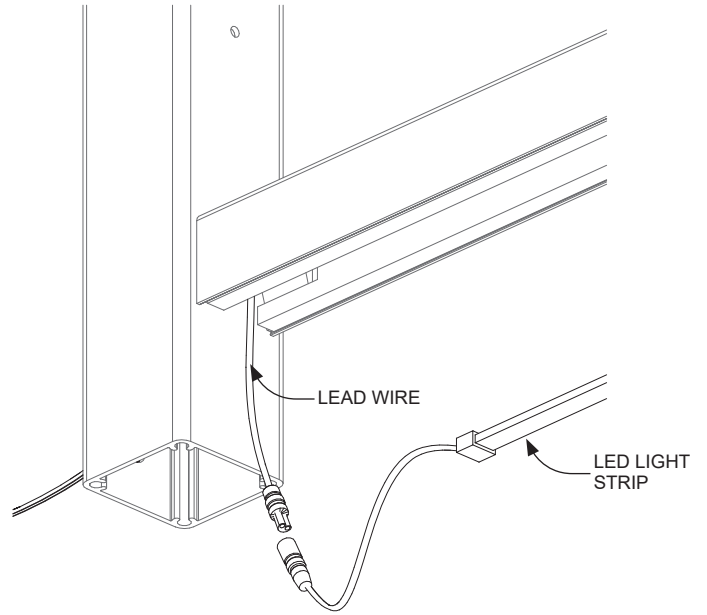

Figure 3.4

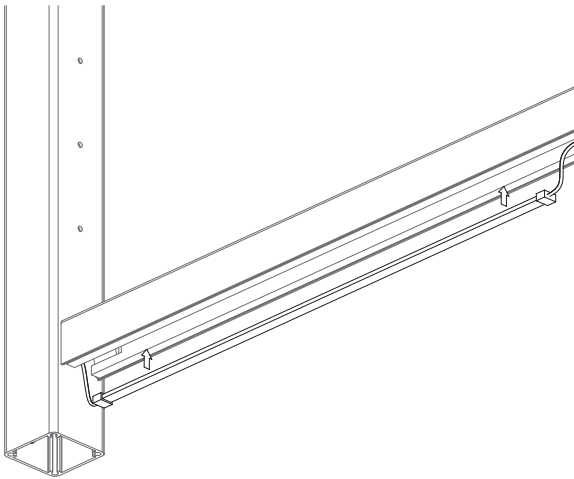

Figure 3.5

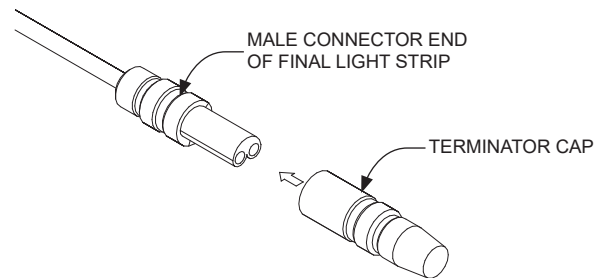

Figure 3.6

Step 3 - Install Diffuser Lens

Measure opening between the post faces beneath the bottom rail (See Figure 3.7).

Cut diffuser lens to length, using a sharp utility knife, or heavy duty utility scissors/shears.

Depending on the length of the bottom rail it may require more than one piece of diffuser lens to fill the entire length. In this case, insert the full 48" lens, then trim the second lens to fit the remainder of the opening.

Insert diffuser lens into bottom rail infill, as shown (See Figure 3.8).

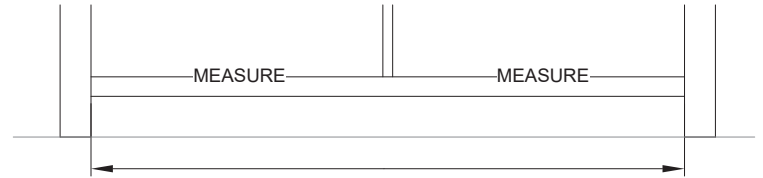

Figure 3.7

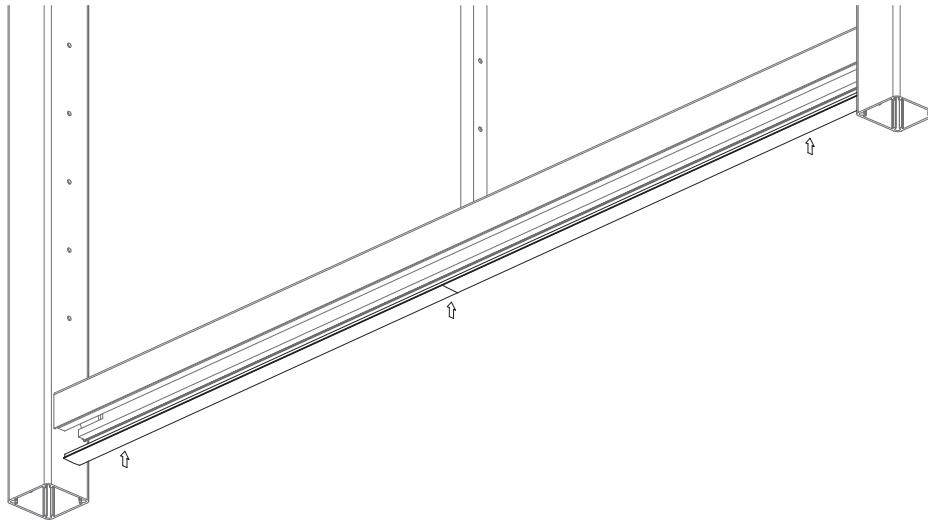

Figure 3.8